



# GTO-GT1

Product User Guide



## APPLICABLE MODELS

This user guide is applicable to the following GTO and GT1 product model SKUs:

**GTO**

**GTOK**

**GT1**

**GT1K**

## NOTICES

### SUMMARY OF WARRANTY TERMS

#### 1. GENERAL STATEMENT OF WARRANTY

Geoforce warrants that for one year from that date that title passes to Customer for Hardware (the "Warranty Period"), the Hardware sold will be free of defects in materials and workmanship when installed, operated, and serviced in strict accordance with Geoforce's and the manufacturer's requirements. Geoforce will, at its sole option and at no charge to Customer, refund, repair, or send a replacement for the Hardware to the location of initial export from a Geoforce affiliate noting Customer as the importer/exporter of record (if outside the US).

#### 2. EXCEPTIONS FROM WARRANTY COVERAGE

This warranty does not cover: (a) Hardware that has been tampered with or serviced without Geoforce's authorization, (b) Hardware that has been lost or stolen through no fault of Geoforce, (c) Hardware that is designed to be consumable (including batteries and battery related failures) or (d) Hardware subjected to abuse, misuse, or neglect, or (e) Hardware that has been deemed failed due to improper operational use or mis-matched to ineffective use-case by the customer. Geoforce does not warrant that the hardware will meet customer's needs or expectations or that any piece of hardware will work on any particular networks. ALL OTHER WARRANTIES ARE EXPRESSLY DISCLAIMED INCLUDING THE WARRANTY OF MERCHANTABILITY AND FITNESS FOR A PARTICULAR PURPOSE.

#### 3. ADDITIONAL WARRANTY TERMS

See the fully executed Geoforce purchase agreement and Statement of Warranty for a complete statement of warranty terms.



## REGULATORY COMPLIANCE STATEMENT

The customer is responsible for maintaining compliance with all legal, regulatory, and safety-related requirements concerning the use of Geoforce products in the customer's applications, notwithstanding any applications related information or support that may be provided by Geoforce. Deviating from the provided installation instructions or making modifications to the equipment that are not explicitly authorized by GEOFORCE may cause the equipment to violate safety and wireless regulatory requirements, in which case, the right to operate the equipment is voided.

## RIGHT TO CHANGE MATERIAL

The information and specifications in this document are subject to change without notice.

## COPYRIGHT NOTICE

© 2023, Geoforce Inc. - All Rights Reserved. No portion of this media may be reproduced in any form without permission from Geoforce, except as permitted by U.S. copyright law. For permissions contact Geoforce at [www.geoforce.com](http://www.geoforce.com).

## ABOUT THE GEOFORCE GT0 AND GT1

### GT0

Satellite-based GPS equipment tracking has been around for years, but for many equipment types, previous hardware options were too big or expensive. With its compact size and tough build, the GT0 is ideal for all types of field equipment and shipping containers. The device, paired with Geoforce's Track and Trace web-based software, helps minimize lost revenue, recover lost and misplaced equipment, reduce underutilized equipment, verify billing, and efficiently retrieve and manage inventory.

### GT1

The versatile GT1 tracks assets in locations too challenging for other GPS devices. The GT1's unique rugged metal bezel and hermetically-sealed construction provides durable protection from extreme temperatures, forces and chemicals. The GT1 is not only the world's most rugged device, but also its safest, as it has achieved the highest IECEx/ATEX Zone 0 rating.

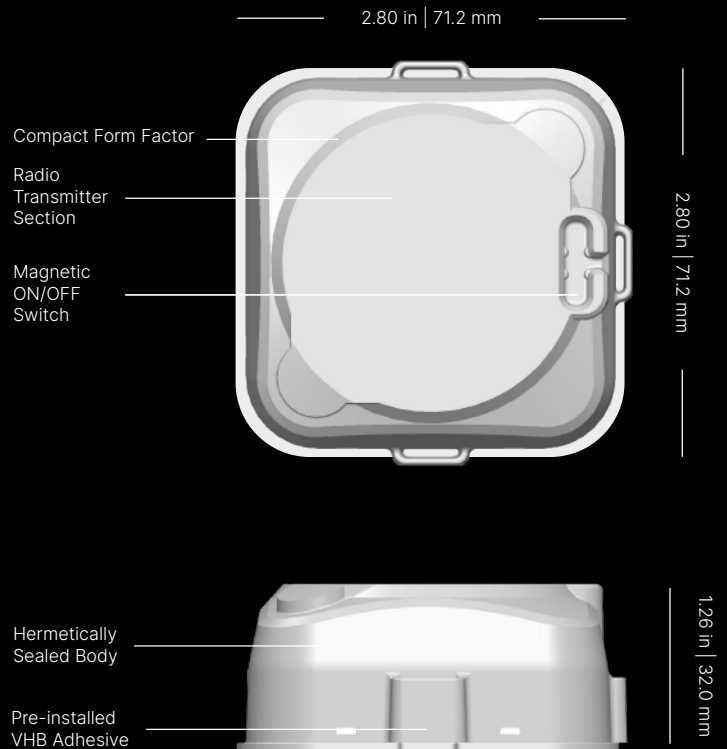

# General Installation and Mounting Guide

## STEP 1: SELECT A MOUNTING LOCATION

To ensure ideal performance it is advised to consider the following:

1. Select a mounting location that provides the best view of the sky.
2. A flat horizontal mounting position (lying flat, facing skyward) is preferred.
3. Vertical mounting orientations (printed face of device facing horizon) are acceptable but may impact performance and overall battery life.
4. Mount on the flattest and hardest surface possible.
5. Select a mounting location that isolates the device from damage.
6. Recommended mounting area size is 5.0" L x 3.5" W (130mmL x 90mmW).
7. Thoroughly clean the mounting area, especially if using VHB mounting.
8. DO NOT PAINT OR COVER THE DEVICE. Doing so may negatively impact product performance and battery life.

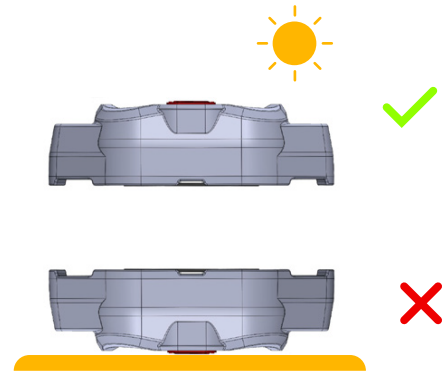

## STEP 2: SELECT A MOUNTING METHOD

### MECHANICAL MOUNTING

The device can be mounted with the following Geoforce mounting accessories:

- Heavy Duty Stainless Steel Mounting Bezel for GT0 and GT1  
(SKU: GTXK-BEZEL-SS)
- Commercial Duty Plastic Mounting Bezel for GT0 and GT1  
(SKU: GTXK-BEZEL-RP)

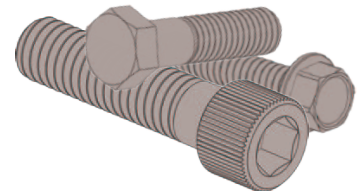

### WELD DOWN MOUNTING

For installations that can allow a welded down and prepared 'Geoforce Ready' surface for the GT0 and GT1. (SKU: GTXK-BASEPLATE)

Additional installation information for each mechanical mounting method is available on the following pages.



### VHB ADHESIVE MOUNTING

For installations that do not require a protective bezel and are isolated from abuse, extreme weather, and temperatures, the device has a pre-installed set of VHB adhesive pads that can be used to "peel and stick" to any clean surface above 50°F (10°C). The Geoforce VHB Installation and Removal Guide MUST be followed to ensure proper adhesion to the asset.

**VHB 'peel and stick' is not recommended if using a protective bezel mounting option.**

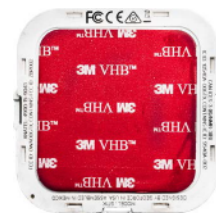

## STEP 3: ASSOCIATE THE DEVICE TO THE ASSET

### Using Geoforce Track and Trace Web Application

1. Record the Device 8-digit numerical serial number (ESN).
2. Record the asset name and serial number (on to which the device was installed).
3. Login to the Track and Trace application, select (or create) the asset, and assign the device ESN to the asset.



### Using Geoforce Mobile Field Tools Mobile App

1. Open the Geoforce Mobile Field Tools application.
2. Select (or create) the asset in mobile field tools.
3. Scan the QR code on the top surface of the device to assign the device to the asset.



For additional information on device installation, association, and using the various Geoforce applications, feel free to contact your Geoforce customer service representative.

<https://helpdesk.geoforce.com>  
helpdesk@geoforce.com  
888.574.3878

## STEP 4: INITIALIZE THE GT2

### TO BEGIN SERVICE

Using the pull tab, remove the magnet while outdoors with a good sky view.

### TO SUSPEND DEVICE OPERATION

To put the device back into inventory storage mode, reinsert the pulltab magnet back into the device magnet slot.

**NOTE:** Saving the pulltab magnet is recommended for future disabling of the device.



**WARNING: IF YOU DO NOT REMOVE THE MAGNET, THE DEVICE WILL NOT WORK!**

## Metal Bezel Mounting Guide

### STEP 1: SELECT MOUNTING HARDWARE

#### SOCKET-HEAD CAP SCREWS (3/8" BOLT DIAMETER) - STRUCTURAL

For installations that can be drilled and tapped and do not have access to the back side of the mounting surface.





**EXAMPLE OPTION 1 (LESS HARSH ENVIRONMENTS):**

Vendor: McMaster Carr ([www.mcmaster.com](http://www.mcmaster.com)), Part Number: **96006A922**

Description: Black Oxide 18-8 Stainless Steel Socket Head Cap Screw 3/8"

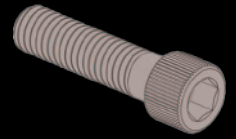
**EXAMPLE OPTION 2 (MORE HARSH ENVIRONMENTS):**

Vendor: McMaster Carr ([www.mcmaster.com](http://www.mcmaster.com)), Part Number: **92185A677**

Description: Type 316 Stainless Steel Socket Head Cap Screw 3/8"

**HEX-HEAD CAP SCREWS (3/8" BOLT DIAMETER) - STRUCTURAL**

For installations having access to the back side of the mounting surface for securing a nut.

**EXAMPLE OPTION 1 (LESS HARSH ENVIRONMENTS):**

Vendor: McMaster Carr ([www.mcmaster.com](http://www.mcmaster.com)), Part Number: **92198A628**

Description: 18-8 Stainless Steel Hex Head Cap Screw 3/8"

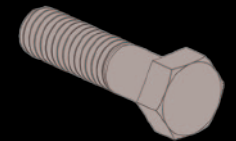
**EXAMPLE OPTION 2 (MORE HARSH ENVIRONMENTS):**

Vendor: McMaster Carr ([www.mcmaster.com](http://www.mcmaster.com)), Part Number: **93190A367**

Description: Type 316 Stainless Steel Hex Head Cap Screw 3/8"

**SELF-DRILLING SHEET-METAL SCREWS (1/4" DIAMETER) - NONSTRUCTURAL**

For installations with thinner mounting surfaces where a quicker less robust install is needed.

Vendor: McMaster Carr ([www.mcmaster.com](http://www.mcmaster.com)), Part Number: **90822A630**

Description: Stainless Steel Drilling Screw for Metal, High-Strength, 1/4"

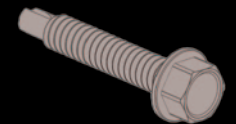
**METAL BANDING - NONSTRUCTURAL**

For securing the metal mounting bezel when bolts or screws cannot be used.

Tip: This is also good for providing a security seal around the installed GT2 bezel mounting bolts.

Vendor: McMaster Carr ([www.mcmaster.com](http://www.mcmaster.com))

Banding Part Number: **5422K42**

Description: Low-Profile Hose Banding Type 201 Stainless Steel, 1/4" Wide, 0.020" Thick

Buckle Part Number: **5422K43**

Description: Type 201 Stainless Steel Ear Style Buckle for 3/8" Wide Low-Profile Hose Banding

Tooling Part Number: **5424K3**

## STEP 2: INSTALL

1. Drill two mounting holes 3.625" (92mm) apart for 3/8" diameter bolts. Thread the holes if needed.
2. Clean the mounting surface of drill shavings.
3. Hand press the device into the metal bezel and secure the assembly onto the flat mounting surface with the required hardware.

## IMPORTANT NOTES

- It is highly recommended to use mounting fasteners made of a material that resists galvanic corrosion and environmental weathering such as stainless steel. This is especially important for marine applications where a high grade should be used.
- To avoid staining and discoloration, zinc coated mounting hardware should not be used.

- When using stainless steel mounting hardware, it is highly recommended to use a marine grade anti-seize material on the bolt threads as galling and seizing of stainless nuts/bolts may occur.
- Ensure all mounting hardware is compatible with the asset.
- Ensure all regulatory and asset owner policies and procedures are adhered to during installation.
- NOTE FOR EX RATED PRODUCTS: To minimize electrostatic spark concerns in hazardous locations, ensure the metal mounting bezel has metal to metal contact with the asset (mounting hardware can provide metal to metal contact as well).

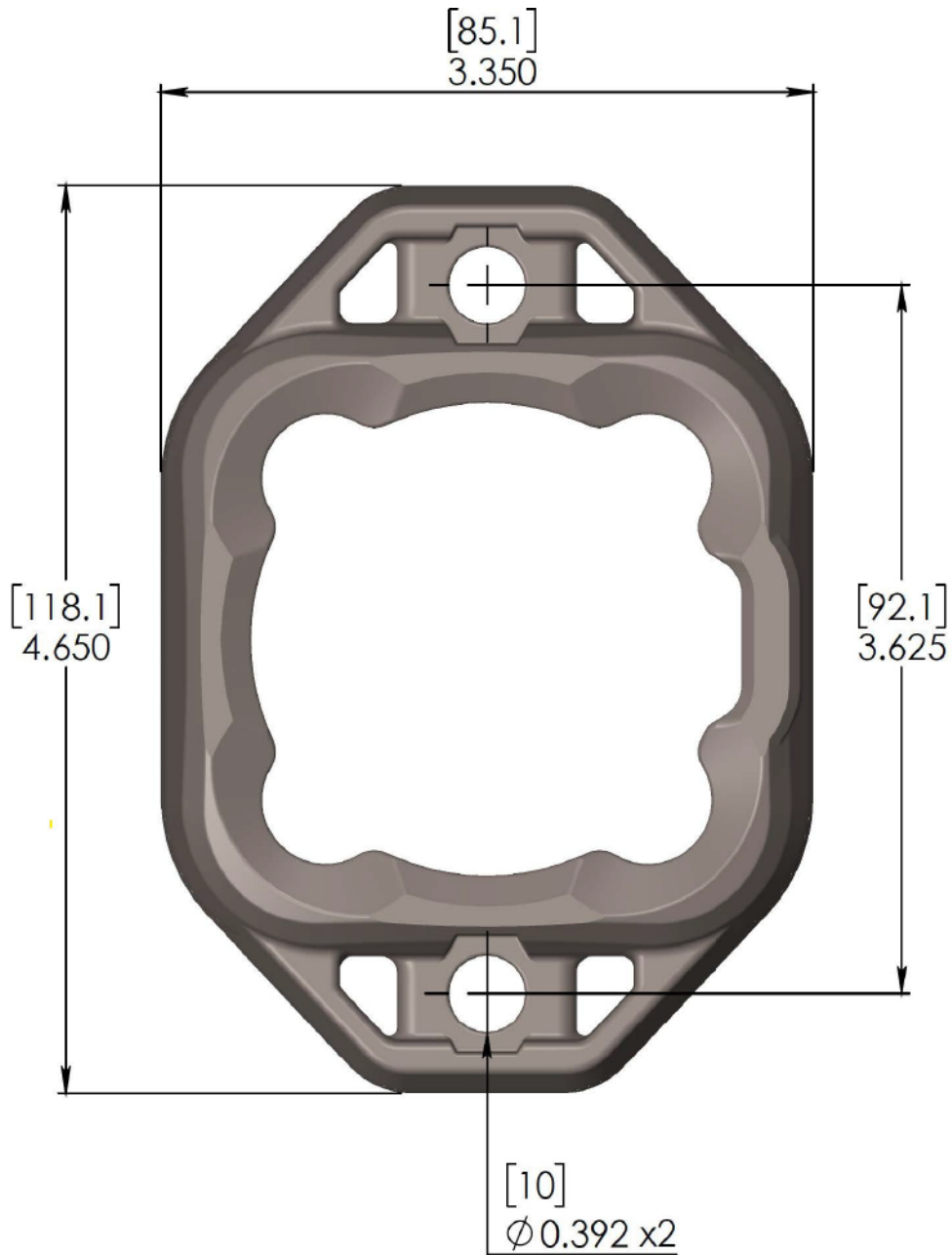

BEZEL MATERIAL: 316L STAINLESS STEEL

NOTE: USE WITH 3/8" HEX OR SOCKET HEAD CAP SCREWS. NOTE: HEX HEAD CAP SCREWS ARE CAPTURED

# Plastic Bezel Mounting Guide

## STEP 1: SELECT MOUNTING HARDWARE

### SOCKET-HEAD CAP SCREWS (1/4" BOLT DIAMETER) - STRUCTURAL

For installations that can be drilled and tapped and do not have access to the back side of the mounting surface

#### EXAMPLE OPTION 1 (LESS HARSH ENVIRONMENTS):

Vendor: McMaster Carr ([www.mcmaster.com](http://www.mcmaster.com)), Part Number: **96006A922**

Description: Black Oxide 18-8 Stainless Steel Socket Head Cap Screw 3/8"

#### EXAMPLE OPTION 2 (MORE HARSH ENVIRONMENTS):

Vendor: McMaster Carr ([www.mcmaster.com](http://www.mcmaster.com)), Part Number: **92185A677**

Description: Type 316 Stainless Steel Socket Head Cap Screw 3/8"

### HEX-HEAD CAP SCREWS (1/4" BOLT DIAMETER) - STRUCTURAL

For installations having access to the back side of the mounting surface for securing a nut.

#### EXAMPLE OPTION 1 (LESS HARSH ENVIRONMENTS):

Vendor: McMaster Carr ([www.mcmaster.com](http://www.mcmaster.com)), Part Number: **92198A111**

Description: 18-8 Stainless Steel Hex Head Screw 1/4"-28 Thread Size

#### EXAMPLE OPTION 2 (MORE HARSH ENVIRONMENTS):

Vendor: McMaster Carr ([www.mcmaster.com](http://www.mcmaster.com)), Part Number: **91287A142**

Description: 18-8 Stainless Steel Hex Head Screw M6 × 1 mm Thread

### SELF-DRILLING SHEET-METAL SCREWS (#12 DIAMETER) - NONSTRUCTURAL

For installations with thinner mounting surfaces where a quicker less robust install is needed.

Vendor: McMaster Carr ([www.mcmaster.com](http://www.mcmaster.com)), Part Number: **92364A269**

Description: Stainless Steel Drilling Screw for Metal, High-Strength, #12

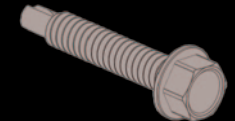
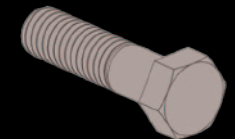
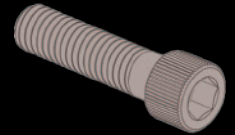

## STEP 2: INSTALL

1. Drill two mounting holes 3.625" (184mm) apart for 1/4" bolts. Thread the holes if needed.
2. Clean the mounting surface of drill shavings.
3. Hand press the GT2 into the device until it snaps in place and secure the assembly onto the mounting surface with the required hardware.

## IMPORTANT NOTES

- It is highly recommended to use mounting fasteners made of a material that resists galvanic corrosion and environmental weathering such as stainless steel. This is especially important for marine applications where a high grade should be used.
- When using stainless steel mounting hardware, it is highly recommended to use a marine grade anti-seize material on the bolt threads as galling and seizing of stainless nuts and stainless bolts may occur.

- Ensure all mounting hardware is compatible with the asset.
- Ensure all regulatory and asset owner policies and procedures are adhered to during installation.

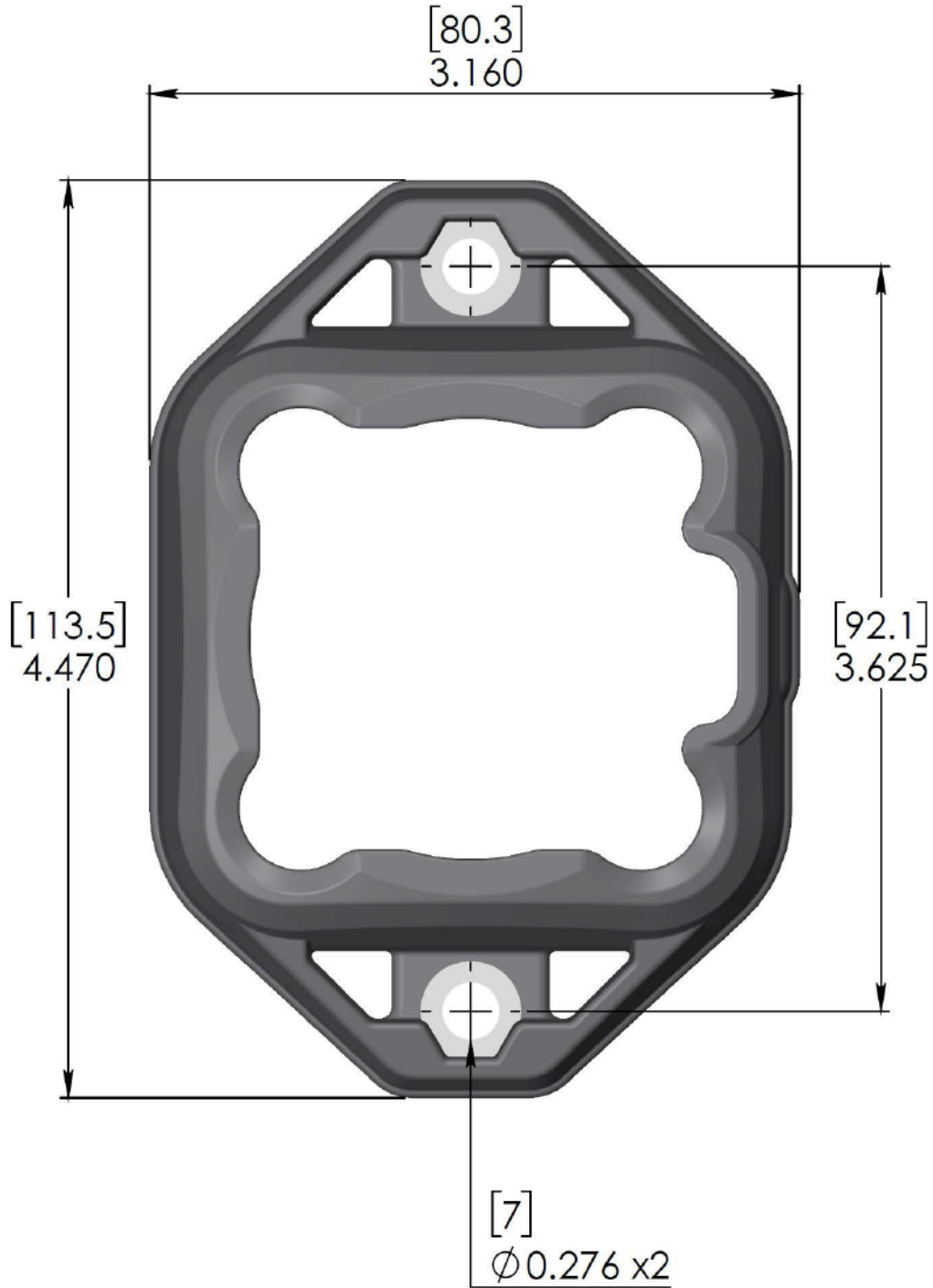

NOTE: USE WITH 3/8" HEX OR SOCKET HEAD CAP SCREWS. NOTE: HEX HEAD CAP SCREWS ARE CAPTURED.

# Weld Down Baseplate Mounting Guide

## STEP 1: PREPARE FOR THE INSTALLATION

1. To ensure a solid weld first clean the selected mounting area of any paint or contamination that may interfere with the desired welding process. Clean the baseplate.
2. Position the baseplate and secure with a welding fixture, magnet, or holding clamp as appropriate to prevent warp.

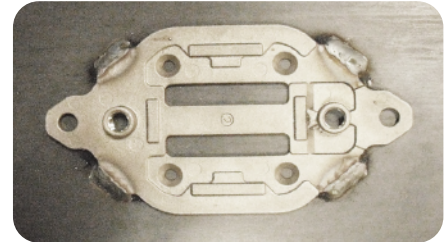
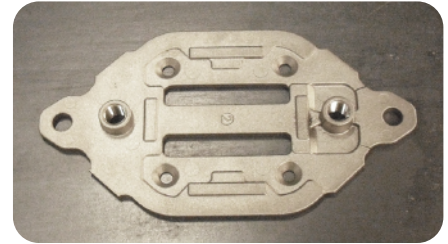

## STEP 2: WELD IN PLACE

1. Tack in place and then weld four ~0.75" (~20mm) fillet weld seams at the four corner ears (cross pattern recommended).
2. Paint may be applied over the baseplate to seal the welds and allow for asset color matching.

NOTE: It is highly recommended to use plastic caps or masks over the threaded bosses or plug the threaded holes during painting processes to prevent clogged threads and the need for additional cleanup.

3. Install the device and the heavy-duty metal mounting bezel onto the baseplate normally per this guide.

NOTE: The recommended torque on the Geoforce provided 3/8" coated bolts securing the bezel to the weld-down/adaptor plate is **22.0 ftlbs +/- 2.0 ftlb (30.0 Nm +/- 2.7 Nm)**.



## IMPORTANT NOTES

- All asset regulatory compliance, certification and asset owner policies and procedures must be followed.
- The bolts provided by Geoforce are coated with a material to mitigate thread galling. The coating also provides long term medium thread locking support. It is highly recommended to use these bolts. If the bolts provided by Geoforce are not used for any reason then it is highly recommended that a marine grade anti-seize material be used on the bolt threads to prevent thread galling and seizing with the baseplate.

# Weld Down Baseplate Installation Drawing

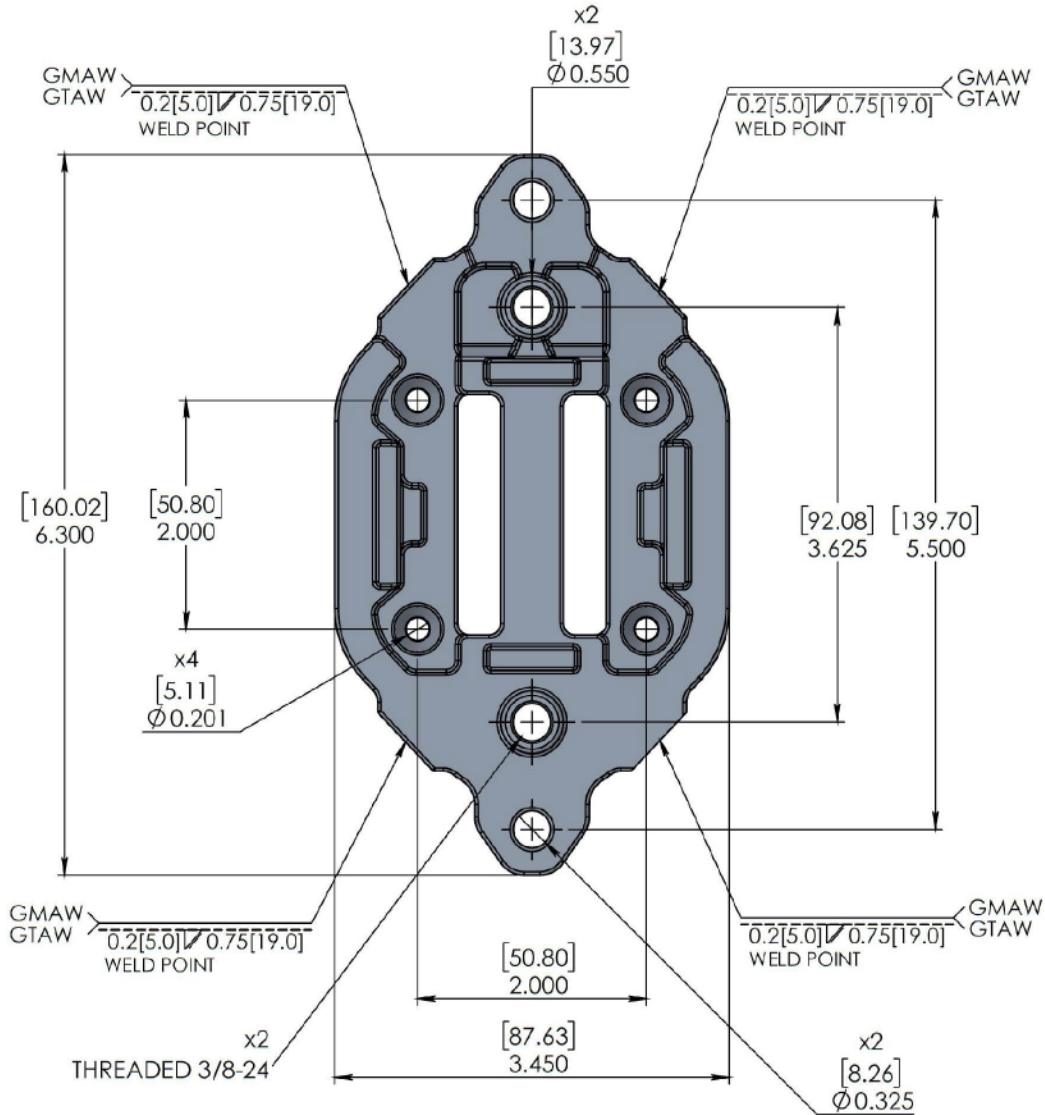

## IMPORTANT NOTES

- The weld down baseplate is a 316L stainless steel that can be welded easily to a variety of mild, alloy and stainless steel materials. The weld is considered non-structural.
- To lower the chances of long term corrosion on the welds a stainless steel filler or weld wire such as ER316L or ER308L is recommended.
- For marine environments it is recommend to exercise allcaution in preventing long term corrosion and weathering effects by using the best welding practices, materials and coatings (if required) for those situations.

# General Maintenance

## DEVICE CLEANING

The device is maintenance free other than general upkeep for cleanliness to maintain normal device operation. To maintain a long product life and optimal performance the device should be kept as clean as possible of dirt, grease, and chemical buildups.

Clean the device with mild soap and water only. Aggressive chemicals and/or corrosive agents may damage and/or deform the device plastic enclosure and window.

## DEVICE CLEANING FOR EX RATED PRODUCTS IN HAZARDOUS LOCATIONS

When working with or cleaning the device, Geoforce recommends to do so outside of hazardous locations. If this is not possible, Geoforce recommends to be mindful at all times of electro-static discharge (ESD) shock hazards and ESD avoidance by using proper grounding techniques when touching this device or the asset it is mounted on. Clean with mild soap/water and a damp cloth only. Allow the device to dry naturally.

## METAL BEZEL CLEANLINESS

Light amounts of red rust may occur on the device metal bezel. This red rust generally originates from free iron, surface deposits, and general contamination from weathering and dirt. The presence of light amounts of red rust does not affect the integrity or function of the product and does not originate from the metal part structure.

## DISPOSAL NOTICE

Warning: Do not dispose of product or batteries in municipal waste areas. Geoforce recommends to dispose of old retired devices in acceptable local e-waste recycling locations.

**<https://helpdesk.geoforce.com>**  
**[helpdesk@geoforce.com](mailto:helpdesk@geoforce.com)**  
**888.574.3878**

## Notes

---

---

---

---

---

---

---

---

---

---